

145/146 Twin Spark Serpentine belts

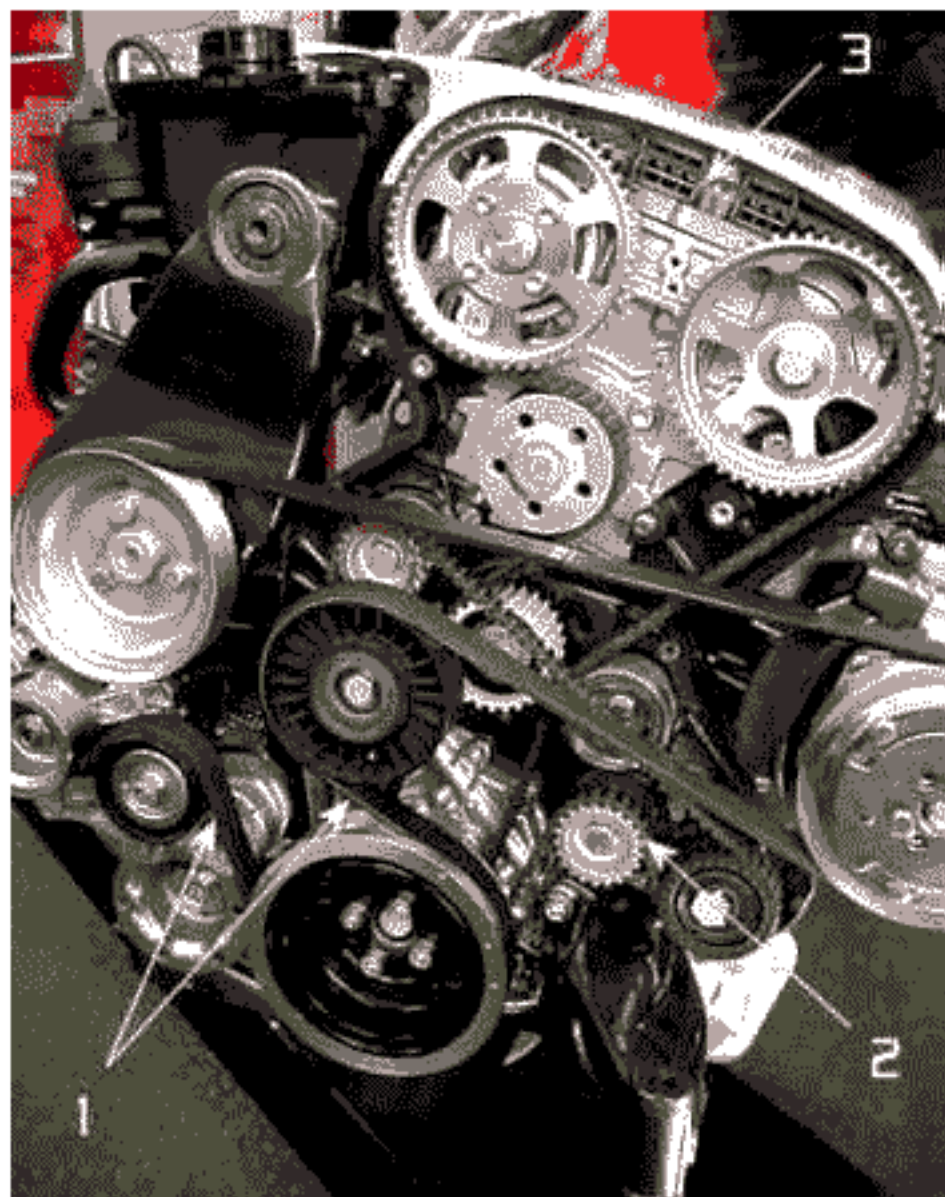

ALFA ROMEO

Model:	33 Sport Wagon 1,3 +4x4 • 33 1,5 • 33 Sport Wagon 1,5ie +4x4 33 1,7 Cloverleaf • 33 1,7 Veloce • 33 1,7 i.e.
Year:	1986-94
Engine Code:	305.50, 305.58A, 307.32, 307.34, 307.36, 307.37, 307.46, 307.47, 307.50, 307.51



Replacement Interval Guide

Alfa Romeo recommend check & replace if necessary every 12,000 miles and replacement every 48,000 miles.

The previous use and service history of the vehicle must always be taken into account.

Refer to Timing Belt Replacement Intervals at the front of this manual.

Check For Engine Damage

CAUTION: This engine has been identified as an **INTERFERENCE** engine in which the possibility of valve-to-piston damage in the event of a timing belt failure is **MOST LIKELY** to occur.

A compression check of all cylinders should be performed before removing the cylinder head.

Repair Times – hrs

Remove & install:

Both belts	1,35
RH belt only	1,05

Special Tools

- None required.

Special Precautions

- Disconnect battery earth lead.
- DO NOT turn crankshaft or camshaft when timing belt removed.
- Remove spark plugs to ease turning engine.
- Turn engine in normal direction of rotation (unless otherwise stated).
- DO NOT turn engine via camshaft or other sprockets.
- Observe all tightening torques.

Removal

NOTE: Engine fitted with hydraulic tappets.

1. Remove:
 - Cooling fan.
 - Auxiliary drive belt.
 - Timing belt covers 1 & 2.
2. Turn crankshaft to TDC on No.1 cylinder. Ensure flywheel timing mark aligned 3. Ensure marks on camshafts in timing belt rear cover aligned 4 & 5.
3. Slacken RH tensioner nut. Move tensioner away from belt and lightly tighten nut.
4. Slacken LH tensioner nut. Move tensioner away from belt and lightly tighten nut.
5. Remove:
 - RH timing belt.
 - LH timing belt.

Installation

1. If camshafts/crankshaft have been disturbed: Turn crankshaft 45° anti-clockwise from TDC mark to prevent piston/valve contact 1.
2. Turn LH camshaft until timing mark aligned 4.
3. Turn crankshaft clockwise until timing mark aligned 3.
4. Fit LH timing belt.
5. Slacken LH tensioner nut. Allow tensioner to operate and lightly tighten nut.
6. Turn crankshaft 45° anti-clockwise from TDC mark 3.
7. Turn RH camshaft until timing marks aligned 5.
8. Turn crankshaft until timing mark aligned 3.
9. Fit RH timing belt.
10. Slacken RH tensioner nut. Allow tensioner to operate and lightly tighten nut.
11. Turn crankshaft two turns clockwise to position RH cam lobes in neutral position.
12. Slacken RH tensioner nut, then tighten to 37-46 Nm.
13. Turn crankshaft one turn clockwise to position LH cam lobes in neutral position.
14. Slacken LH tensioner nut, then tighten to 37-46 Nm.
15. Turn crankshaft clockwise. Ensure timing marks aligned 3, 4 & 5.
16. Install components in reverse order of removal.
17. If tappet(s) are noisy: Allow engine to idle to ensure hydraulic tappets refill with oil.

Ⓜ

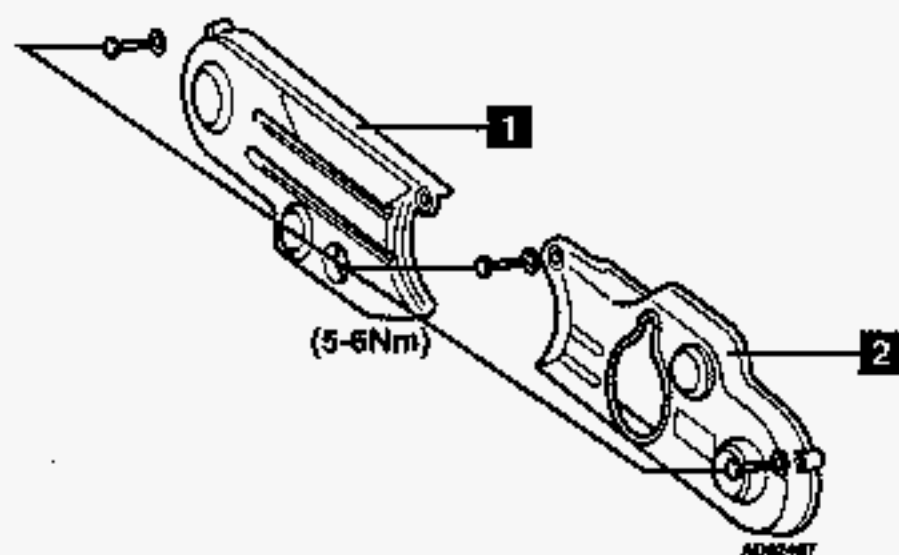
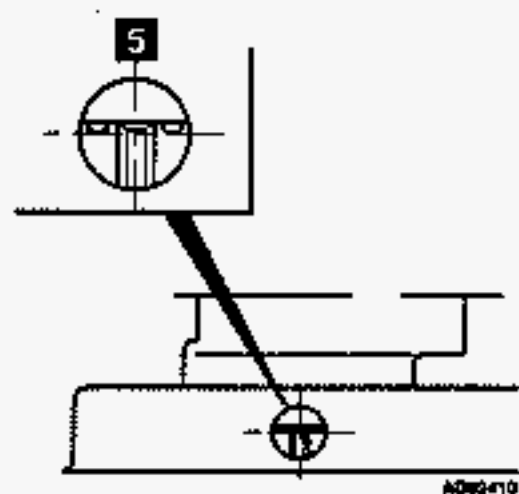
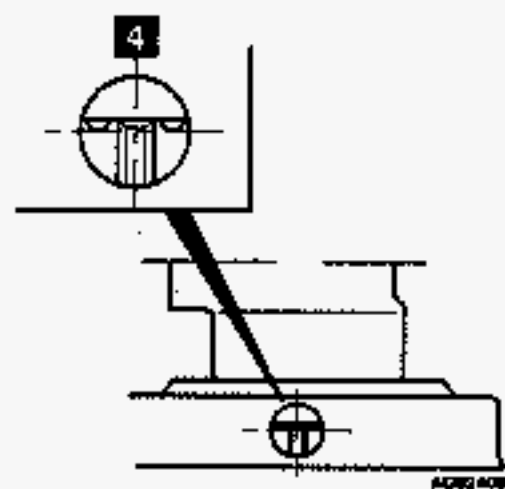
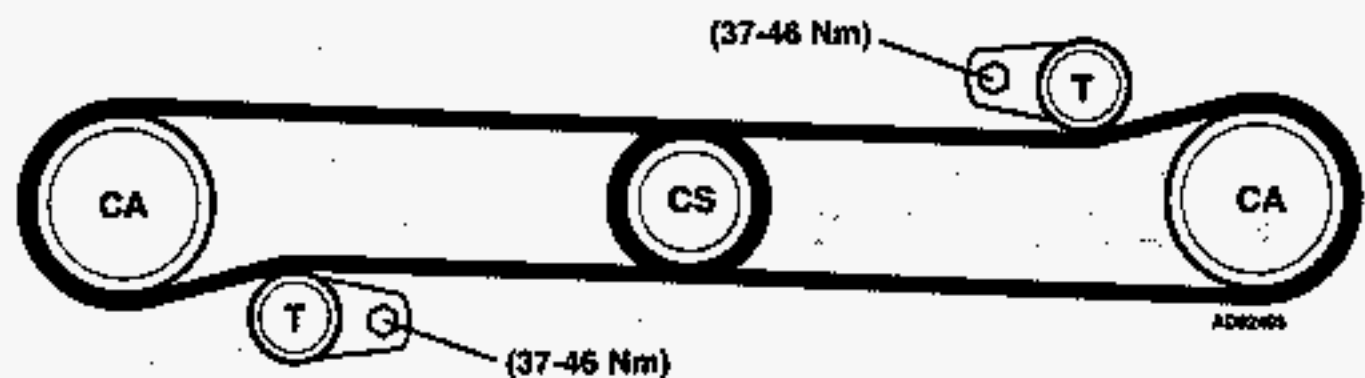
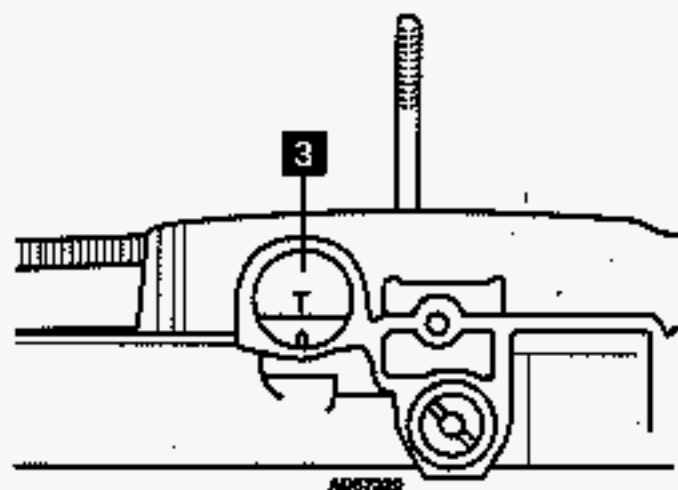

ALFA ROMEO

Model: 33 1,7 16V
Year: 1991-94
Engine Code: 307-46, 307-47



Replacement Interval Guide

Alfa Romeo recommend replacement every 48,000 miles.

The previous use and service history of the vehicle must always be taken into account.

Refer to Timing Belt Replacement Intervals at the front of this manual.

Check For Engine Damage

CAUTION: This engine has been identified as an **INTERFERENCE** engine in which the possibility of valve-to-piston damage in the event of a timing belt failure is **MOST LIKELY** to occur.

A compression check of all cylinders should be performed before removing the cylinder head.

Repair Times - hrs

Remove & install:

Both belts	1,50
RH belt only	1,20

Special Tools

- None required.

Special Precautions

- Disconnect battery earth lead.
- **DO NOT** turn crankshaft or camshaft when timing belt removed.
- Remove spark plugs to ease turning engine.
- Turn engine in normal direction of rotation (unless otherwise stated).
- **DO NOT** turn engine via camshaft or other sprockets.
- Observe all tightening torques.

Removal

1. Remove:

- Cooling fan assembly.
- Spark plugs.
- Auxiliary drive belts.
- Water pump pulley ⑩.
- Timing belt covers ①.

NOTE: Crankshaft damper does not need to be removed.

2. Turn crankshaft until flywheel timing mark and timing marks on camshafts aligned ② & ③.
3. Slacken RH tensioner nuts ④. Move tensioner away from belt and lightly tighten nuts.
4. Slacken LH tensioner nuts ④. Move tensioner away from belt and lightly tighten nuts.
5. Remove:
 - RH timing belt ⑤.
 - LH timing belt ⑥.

Installation

NOTE: Check condition of tensioner springs ⑧ and free movement of tensioner bracket.

1. Ensure timing marks aligned ② & ③.
 2. Fit LH timing belt ⑥. Ensure belt is taut between crankshaft sprocket, guide pulley and exhaust camshaft sprocket ⑧.
 3. Slacken LH tensioner nuts ④. Allow tensioner to contact belt ⑥.
 4. Fit RH timing belt ⑤. Ensure belt is taut between crankshaft sprocket, guide pulley and inlet camshaft sprocket ⑩.
 5. Slacken RH tensioner nuts ④. Allow tensioner to contact belt ⑤.
 6. Turn crankshaft slowly two turns clockwise. Ensure timing belts do not slip.
 7. Ensure timing marks aligned ② & ③.
 8. Tighten LH tensioner nuts ④.
 9. Tighten RH tensioner nuts ④.
 10. Turn crankshaft slowly clockwise until neutral marks aligned ⑪, ⑫ & ⑬.
 11. Slacken LH tensioner nut, then tighten to 37-46 Nm ④.
 12. Slacken RH tensioner nut, then tighten to 37-46 Nm ④.
- NOTE:** Allow tensioners to operate by spring tension only.
13. Install components in reverse order of removal.

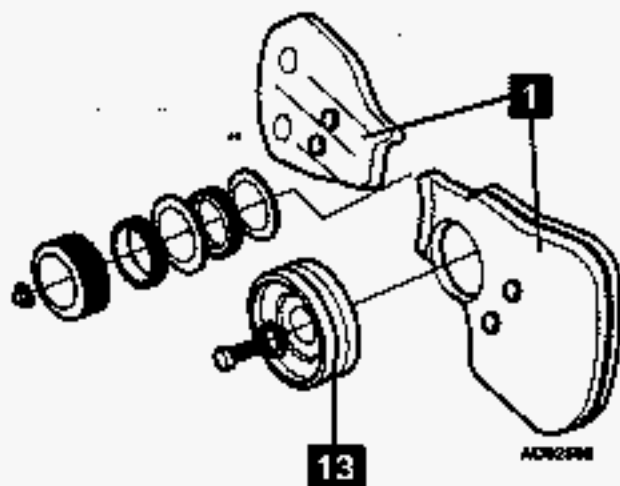
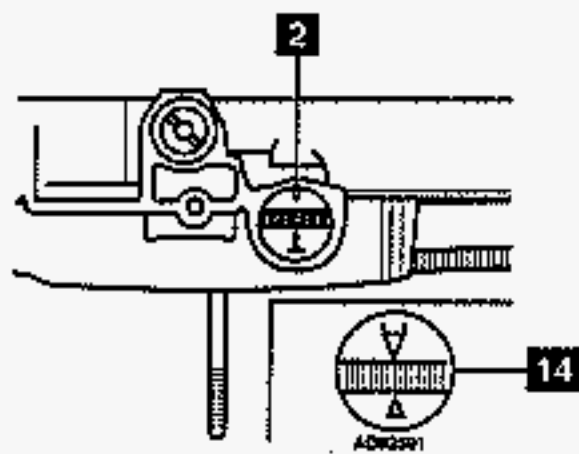
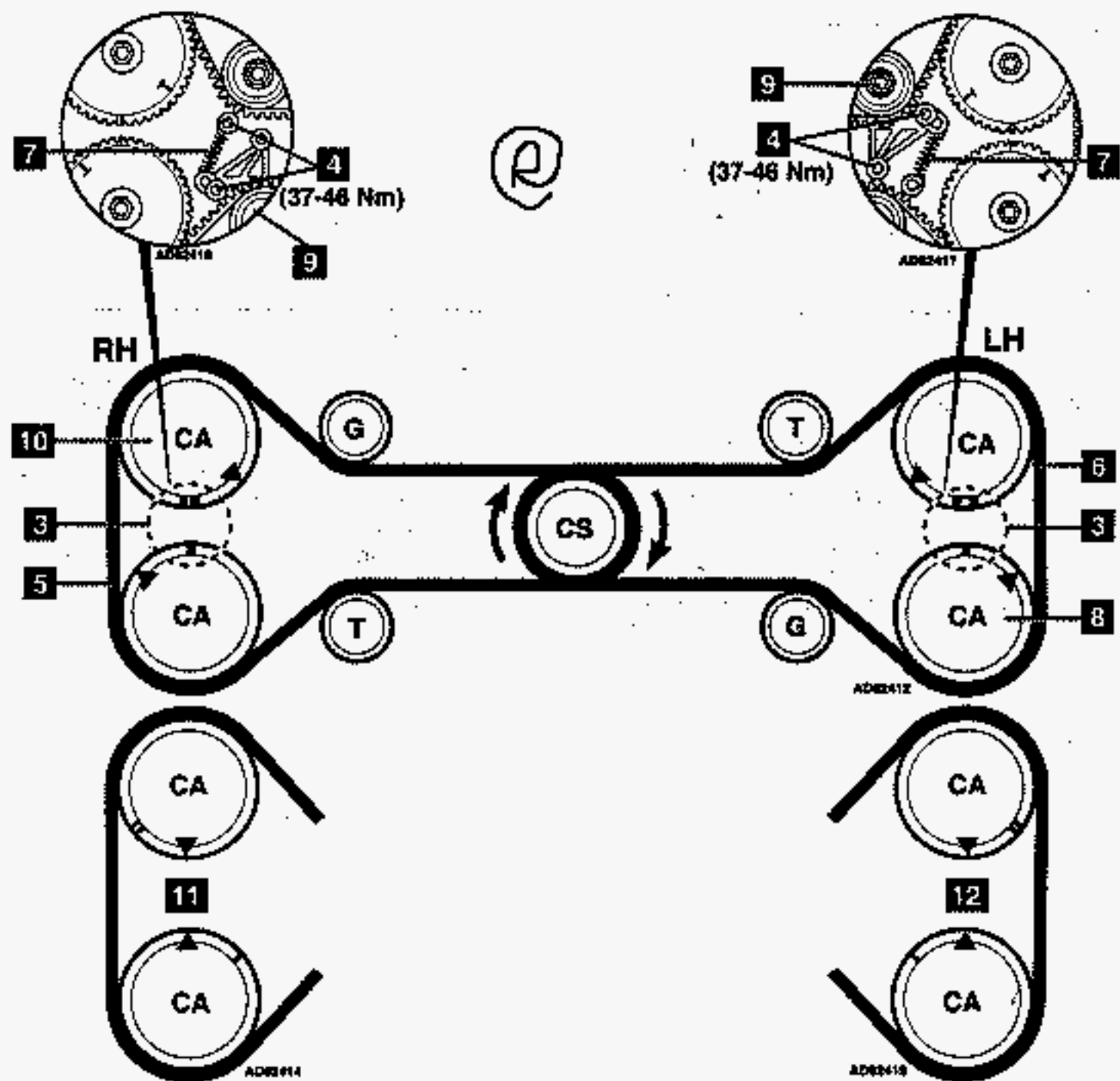

ALFA ROMEO

Model: 145 1,3/1,6 8V • 146 1,3/1,6 8V
Year: 1994-97
Engine Code: AR 332.01, 335.01



Replacement Interval Guide

Alfa Romeo recommend check & adjust every 48,000 miles and replacement every 72,000 miles.

The previous use and service history of the vehicle must always be taken into account. Refer to Timing Belt Replacement Intervals at the front of this manual.

Check For Engine Damage

CAUTION: This engine has been identified as an INTERFERENCE engine in which the possibility of valve-to-piston damage in the event of a timing belt failure is MOST LIKELY to occur.

A compression check of all cylinders should be performed before removing the cylinder head.

Repair Times – hrs

Check & adjust	0,90
Remove & install	1,35

Special Tools

- None required.

Special Precautions

- Disconnect battery earth lead.
- DO NOT turn crankshaft or camshaft when timing belt removed.
- Remove spark plugs to ease turning engine.
- Turn engine in normal direction of rotation (unless otherwise stated).
- DO NOT turn engine via camshaft or other sprockets.
- Observe all tightening torques.

Removal

1. Remove:
 - Cooling fan.
 - Air filter intake pipe.
 - Spark plugs.
2. Turn crankshaft clockwise until flywheel timing marks **1** and timing marks on camshafts aligned **2** & **3**.
NOTE: Timing marks of camshafts aligned when sprocket tooth with half-circle marks either side visible through hole in timing belt rear cover **2** & **3**.
3. Remove:
 - Auxiliary drive belts.
 - Water pump pulley **4**.
 - Timing belt covers **5** & **6**.
4. Slacken RH tensioner nut **7**. Move tensioner away from belt and lightly tighten nut.

5. Remove RH timing belt.
6. Slacken LH tensioner nut **8**. Move tensioner away from belt and lightly tighten nut.
7. Remove LH timing belt.

Installation

1. Ensure timing marks aligned **1**, **2** & **3**.
2. Fit LH timing belt in anti-clockwise direction, starting at crankshaft sprocket.
3. Slacken LH tensioner nut **8**. Allow tensioner to operate and lightly tighten nut.
4. Ensure timing marks aligned **1**, **2** & **3**.
5. Fit RH timing belt in anti-clockwise direction, starting at crankshaft sprocket. Ensure sprockets do not turn during this operation.
6. Slacken tensioner nut **7**. Allow tensioner to operate and lightly tighten nut.
7. Turn crankshaft clockwise several times. Align timing marks **1**, **2** & **3**.
8. Turn crankshaft 90° clockwise until flywheel mark aligned with arrow **4**.
9. Slacken RH tensioner nut, then tighten to 37-46 Nm **7**.
10. Turn crankshaft 360° clockwise until flywheel mark aligned **5**.
11. Slacken LH tensioner nut, then tighten to 37-46 Nm **8**.
12. Turn crankshaft clockwise. Ensure timing marks aligned **1**, **2** & **3**.
13. Install components in reverse order of removal.

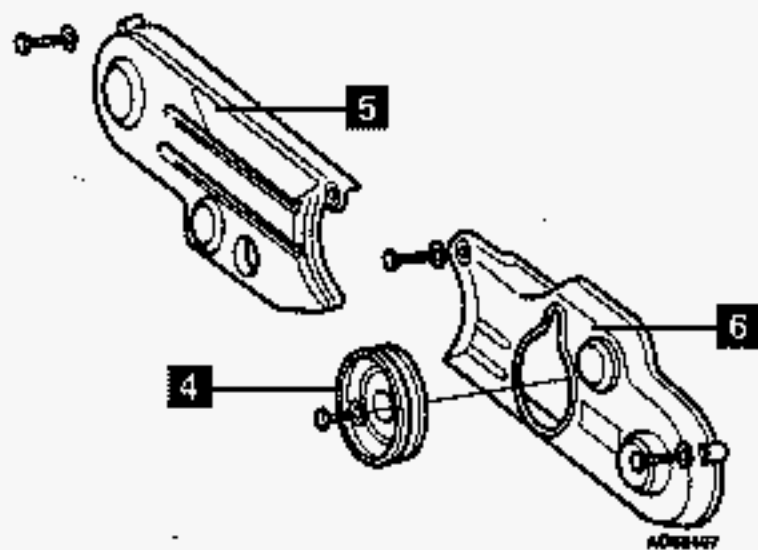
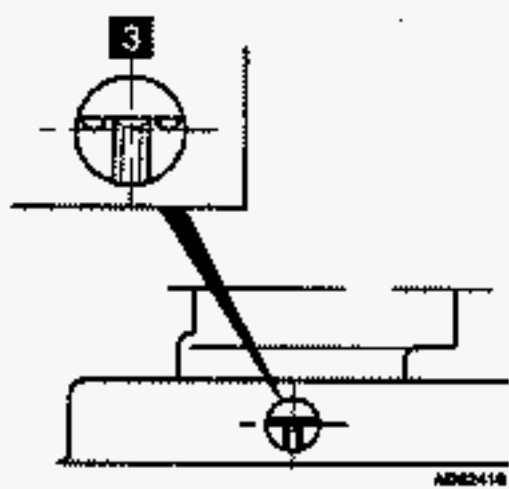
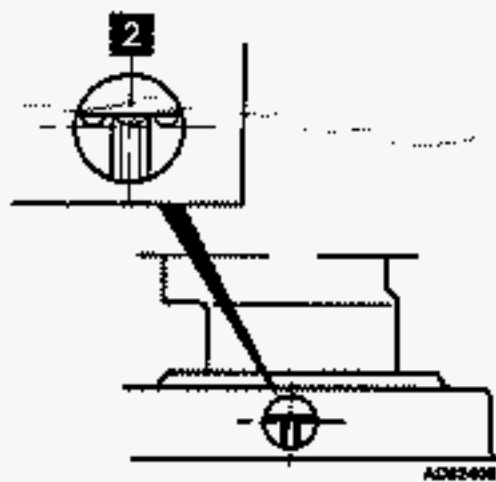
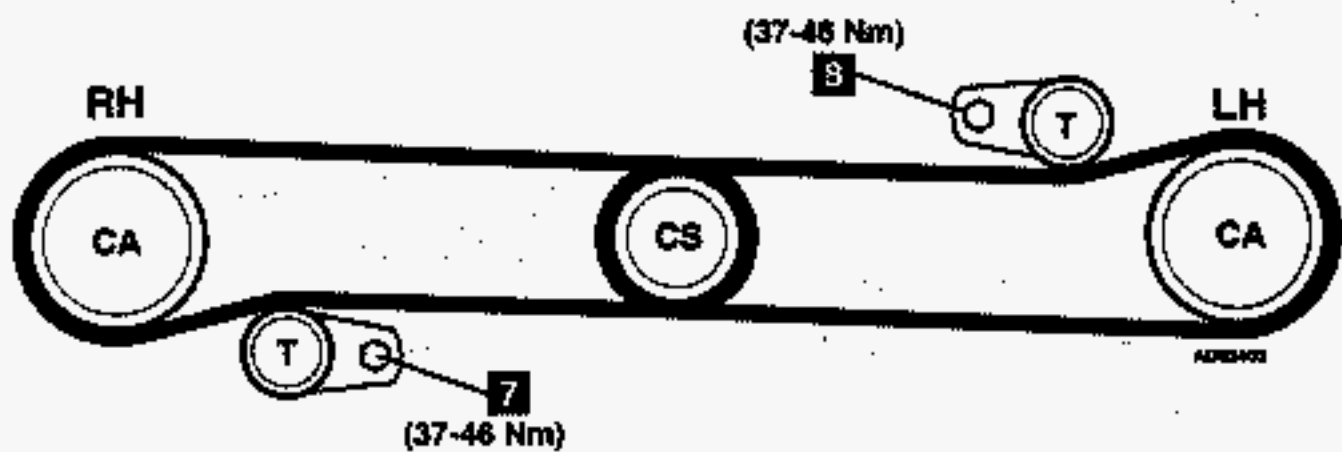
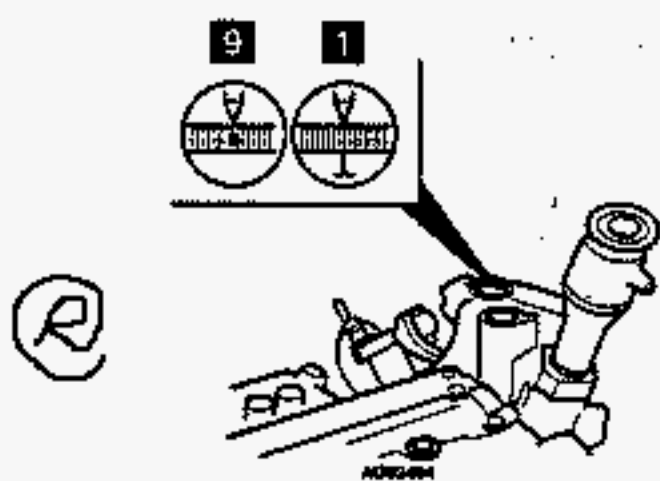

ALFA ROMEO

Model: 145/146 1,4/1,6/1,8 Twin Spark • 155 1,6/1,8 Twin Spark
 156 1,6/1,8 Twin Spark • Spider/GTV 1,8 Twin Spark

Year: 1996-00

Engine Code: AR 322.01, 335.03, 671.06, 676.01



Replacement Interval Guide

Alfa Romeo recommend check 145/146/155/Spider/GTV every 48,000 miles or 4 years.
 Alfa Romeo recommend replacement every 72,000 miles or 6 years.
The previous use and service history of the vehicle must always be taken into account.
 Refer to Timing Belt Replacement Intervals at the front of this manual.

Check For Engine Damage

CAUTION: This engine has been identified as an INTERFERENCE engine in which the possibility of valve-to-piston damage in the event of a timing belt failure is MOST LIKELY to occur.
 A compression check of all cylinders should be performed before removing the cylinder head(s).

Repair Times - hrs

Check:	
145/146/155/Spider/GTV	0,95
Remove & install:	
145/146	2,75
155	2,75
156	2,25
Spider/GTV	2,75

Special Tools

- Camshaft locking tools (1,4/1,6) - Alfa Romeo No.1.825.042.000.
- Camshaft locking tools (1,8) - Alfa Romeo No.1.825.041.000.
- Inlet camshaft holding tool - Alfa Romeo No.1.822.155.000.
- Exhaust camshaft holding tool - Alfa Romeo No.1.822.146.000.
- Timing belt tensioning tool - Alfa Romeo No.1.822.149.000.

Special Precautions

- Disconnect battery earth lead.
- DO NOT turn crankshaft or camshaft when timing belt removed.
- Remove spark plugs to ease turning engine.
- Turn engine in normal direction of rotation (unless otherwise stated).
- DO NOT turn engine via camshaft or other sprockets.
- Observe all tightening torques.

Removal

1. Remove:
 - Auxiliary drive belt.
 - Auxiliary drive belt guide pulley 1.
 - Crankshaft pulley 2.
 - Timing belt upper cover 3.
 - Ignition coils.
 - Cylinder head cover 4.
 - Centre spark plug - cylinder No.1.
2. Insert dial gauge in No.1 cylinder centre plug hole 5.

3. Turn crankshaft slowly to TDC on No.1 cylinder. Use dial gauge.
4. Ensure marks on belt aligned with marks on sprockets 6 & 7.
5. Slacken timing belt tensioner nut 8.
6. Remove timing belt.

Installation

1. Ensure crankshaft at TDC on No.1 cylinder. Use dial gauge 5.
2. Hold camshaft sprockets. Use tool Nos.1.822.155.000 and 1.822.146.000 9 & 10. Slacken bolt of each camshaft sprocket.
3. Remove No.3 inlet and exhaust camshaft bearing caps 11 & 12.
NOTE: Mark bearing caps before removal for identification.
4. Fit locking tools in place of bearing caps 11 & 12. Tool Nos.1.825.041/042.000.
NOTE: Ensure locking tools aligned with respective cam profiles to prevent damage.
5. Fit timing belt in following order:
 - Crankshaft sprocket.
 - Guide pulley.
 - Exhaust camshaft sprocket.
 - Inlet camshaft sprocket.
 - Tensioner pulley.
 - Water pump pulley.
6. Ensure marks on belt aligned with marks on sprockets 6 & 7.
7. Tension timing belt to maximum. Use tool No.1.822.149.000 13.
8. Tighten tensioner nut 8.
9. Hold camshaft sprockets. Use tool Nos.1.822.155.000 and 1.822.146.000 9 & 10.
10. Tighten bolt of each camshaft sprocket.
11. Remove dial gauge 5.
12. Remove locking tools 11 & 12.
13. Fit bearing caps in correct locations.
14. Lubricate camshaft bearing cap bolts. Tighten bolts to 13-16 Nm.
15. Turn crankshaft two turns clockwise to TDC on No.1 cylinder 5.
16. Ensure timing marks aligned 6 & 7.
17. Fit tensioning tool No.1.822.149.000 13.
18. Slacken tensioner nut 8.
19. Turn tensioner until pointer 14 aligned with hole 15.
20. Tighten tensioner nut to 21-26 Nm 8.
21. Turn crankshaft two turns clockwise to TDC on No.1 cylinder 5.
22. Ensure timing marks aligned 6 & 7.
23. Install components in reverse order of removal.
24. Tighten crankshaft pulley bolts to 24-29 Nm.

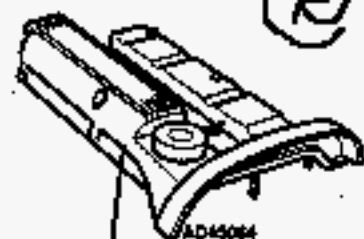

4

(P)

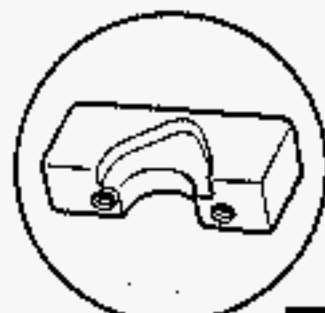

AD43068

11

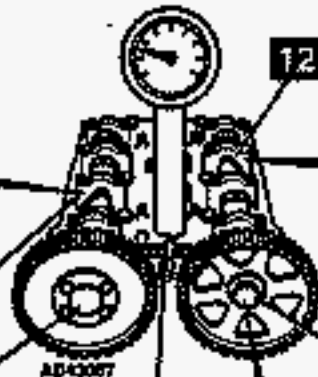

AD43007

5

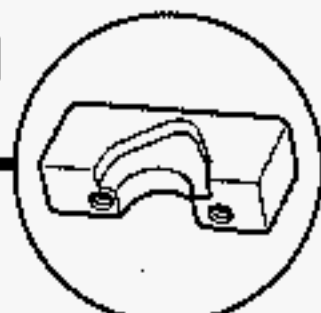

AD43066

12

(100-124 Nm)

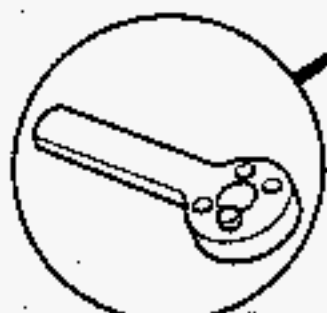

AD43069

9

10

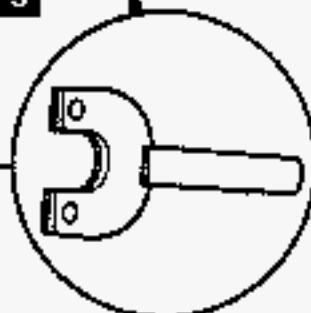

AD43061

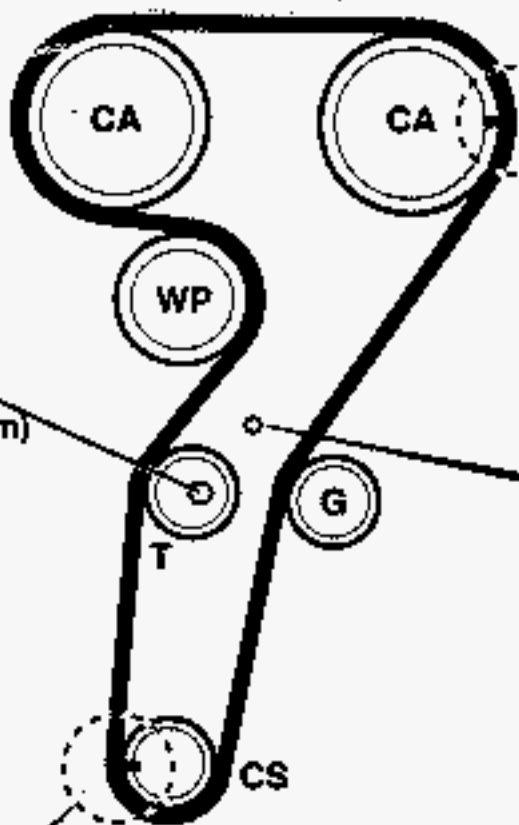

CA

CA

WP

T

G

CS

7



AD43062

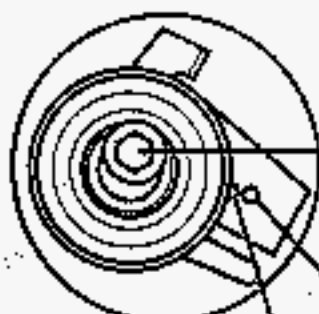

AD43073

8

(21-26 Nm)

15

14

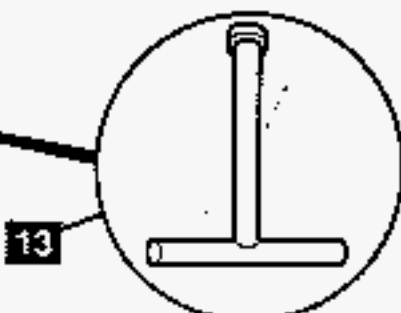

AD43063

13

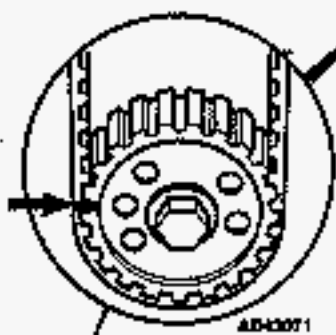

AD43071

6

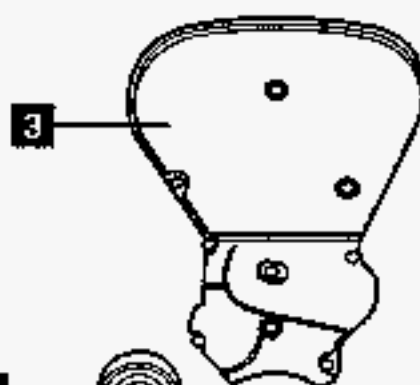

3

1

2

(24-29 Nm)

AD43060

AD11481

Model: 145 1,7 16V • 146 1,7 16V
Year: 1994-97
Engine Code: 334.01



Replacement Interval Guide

Alfa Romeo recommend check & adjust every 48,000 miles and replacement every 72,000 miles.

The previous use and service history of the vehicle must always be taken into account. Refer to Timing Belt Replacement Intervals at the front of this manual.

Check For Engine Damage

CAUTION: This engine has been identified as an INTERFERENCE engine in which the possibility of valve-to-piston damage in the event of a timing belt failure is MOST LIKELY to occur.

A compression check of all cylinders should be performed before removing the cylinder head.

Repair Times - hrs

Check & adjust (including AC)	2,40
Remove & install	1,50
AC	+ 0,95

Special Tools

- None required.

Special Precautions

- Disconnect battery earth lead.
- DO NOT turn crankshaft or camshaft when timing belt removed.
- Remove spark plugs to ease turning engine.
- Turn engine in normal direction of rotation (unless otherwise stated).
- DO NOT turn engine via camshaft or other sprockets.
- Observe all tightening torques.

Removal

NOTE: On models fitted with air conditioning, specialist equipment will be required to drain/recharge AC system.

1. Drain AC system (if fitted).
2. Remove:
 - Radiator grille and bumper.
 - Bonnet release cable from lock.
 - Radiator upper crossmember.
 - Coolant hose from expansion tank.
3. Disconnect radiator hose from thermostat housing.
4. Disconnect electrical connections from cooling fans.
5. Disconnect AC condenser inlet/outlet hoses (if fitted).

6. Remove:

- Radiator complete with fans (and condenser, if fitted).
 - Auxiliary drive belts.
 - Water pump pulley 1.
 - Timing belt covers 2.
 - Spark plugs.
7. Turn crankshaft clockwise until flywheel timing marks and timing marks on camshaft sprockets aligned 3, 4 & 5.
 8. Slacken RH tensioner nuts 6. Move tensioner away from belt and lightly tighten nuts.
 9. Remove RH timing belt.
 10. Slacken LH tensioner nuts 7. Move tensioner away from belt and lightly tighten nuts.
 11. Remove LH timing belt.

Installation

1. Ensure timing marks aligned 3, 4 & 5.
2. Fit LH timing belt in anti-clockwise direction, starting at crankshaft sprocket. Ensure belt is taut between crankshaft sprocket, guide pulley and camshaft sprockets.
3. Slacken LH tensioner nuts 7. Allow tensioner to operate and lightly tighten nuts.
4. Ensure timing marks aligned 3, 4 & 5.
5. Fit RH timing belt in anti-clockwise direction, starting at crankshaft sprocket. Ensure belt is taut between crankshaft sprocket, guide pulley and camshaft sprockets.
6. Slacken RH tensioner nuts 6. Allow tensioner to operate and lightly tighten nuts.
7. Turn crankshaft several times clockwise to settle belts. Ensure timing marks aligned 3, 4 & 5.
8. Turn crankshaft 90° clockwise until flywheel mark and tensioning marks on RH camshaft sprockets aligned 3 & 4.
9. Slacken RH tensioner nuts 6. Allow tensioner to operate and tighten nuts. Tightening torque: 29-36 Nm.
10. Turn crankshaft 360° clockwise until flywheel mark and tensioning marks on LH camshaft sprockets aligned 3 & 4.
11. Slacken LH tensioner nuts 7. Allow tensioner to operate and tighten nuts. Tightening torque: 29-36 Nm.
12. Turn crankshaft several times clockwise. Ensure timing marks aligned 3, 4 & 5.
13. Install components in reverse order of removal.
14. Recharge AC system (if fitted).

(R)

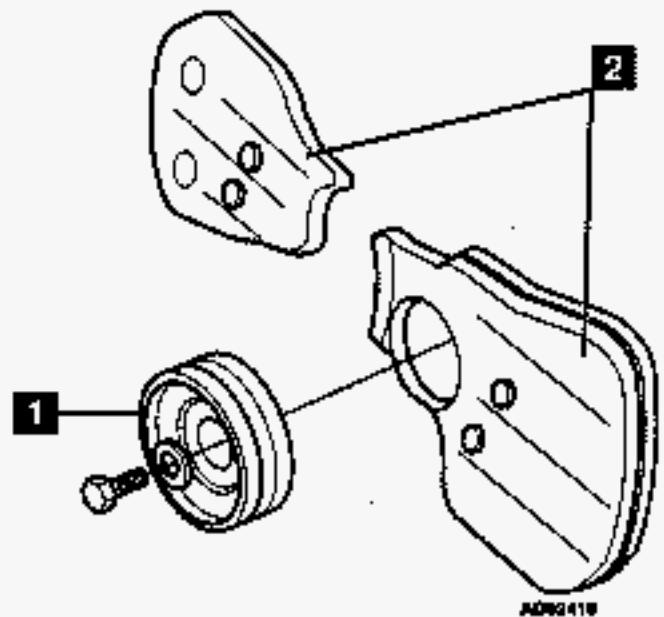
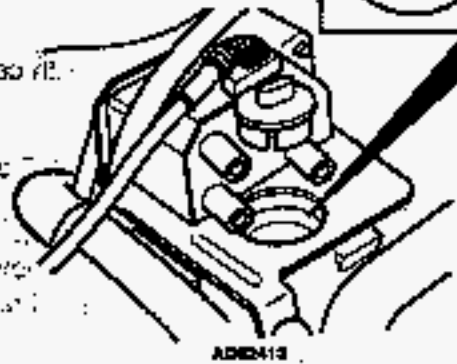
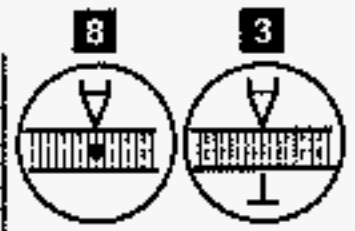
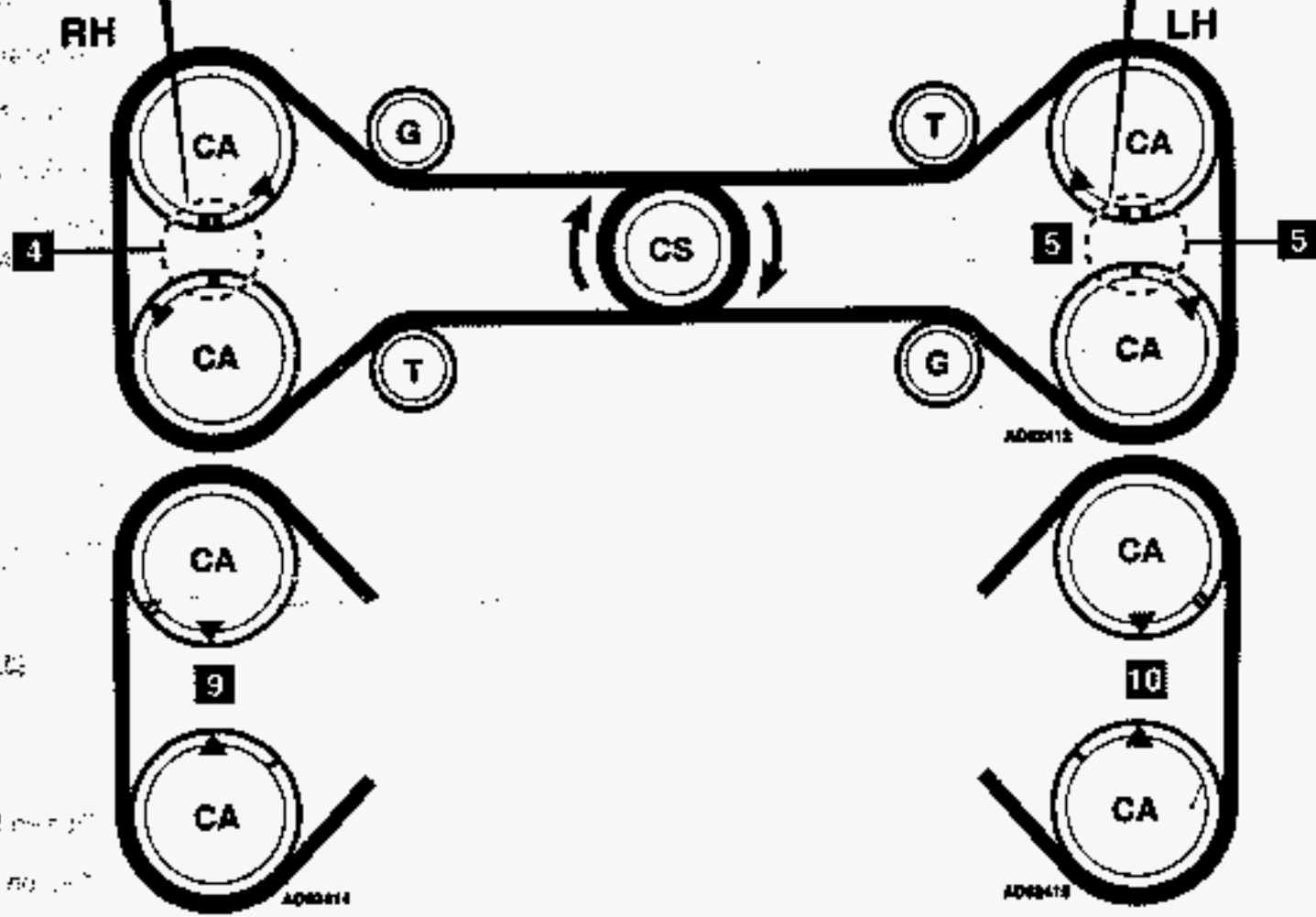
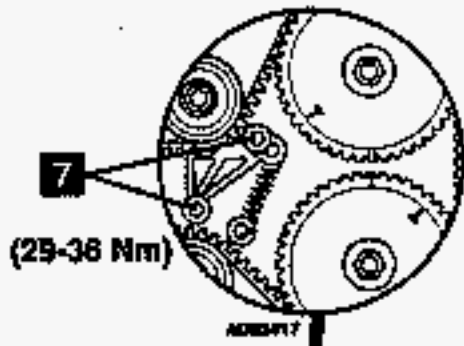
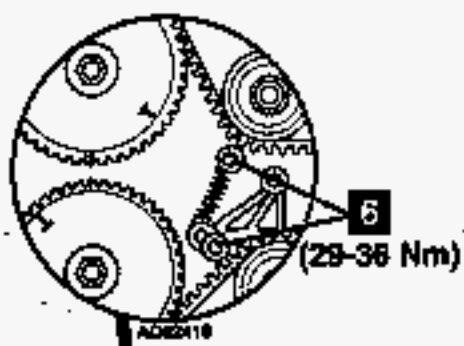

Model: 145/146 2,0 Twin Spark • 155 2,0 Twin Spark • 156 2,0 Twin Spark
Spider/GTV 2,0 Twin Spark • Spider/GTV 2,0 16V

Year: 1995-00

Engine Code: AR 323.01, 672.04, 162.01



Replacement Interval Guide

Alfa Romeo recommend check 145/146/155/Spider/GTV every 48,000 miles or 4 years.

Alfa Romeo recommend replacement every 72,000 miles or 6 years.

The previous use and service history of the vehicle must always be taken into account.

Refer to Timing Belt Replacement Intervals at the front of this manual.

Check For Engine Damage

CAUTION: This engine has been identified as an INTERFERENCE engine in which the possibility of valve-to-piston damage in the event of a timing belt failure is MOST LIKELY to occur.

A compression check of all cylinders should be performed before removing the cylinder head(s).

Repair Times – hrs

Check:	
145/146/155/Spider/GTV	0,95
Remove & install:	
145/146/155	2,90
156	2,95
Spider/GTV	2,90

Special Tools

- Camshaft locking tools – Alfa Romeo No.1.825.041.000.
- Inlet camshaft holding tool – Alfa Romeo No.1.822.155.000.
- Exhaust camshaft holding tool – Alfa Romeo No.1.822.146.000.
- Timing belt tensioning tool – Alfa Romeo No.1.822.149.000.
- Balancer shaft belt tensioning tool – Alfa Romeo No.1.822.154.000.

Removal

1. Remove:
 - Auxiliary drive belt.
 - Crankshaft pulley 1.
 - Timing belt upper cover 2.
 - Timing belt lower cover 3.
 - Ignition coils.
 - Cylinder head cover 4.
 - Centre spark plug – cylinder No.1.
2. Insert dial gauge in No.1 cylinder centre plug hole 5.
3. Turn crankshaft slowly to TDC on No.1 cylinder. Use dial gauge.
4. Ensure balancer shaft marks aligned 7 & 8.
5. Ensure marks on belt aligned with marks on sprockets 9 & 10.
6. Slacken balancer shaft belt tensioner nut 11.
7. Remove balancer shaft belt.
8. Remove balancer shaft belt sprocket from crankshaft 12.
9. Slacken timing belt tensioner nut 13.
10. Remove timing belt.

Installation

1. Ensure crankshaft at TDC on No.1 cylinder. Use dial gauge 14.
2. Hold camshaft sprockets. Use tool Nos.1.822.155.000 and 1.822.146.000 15 & 16. Slacken bolt of each camshaft sprocket.
3. Remove No.3 inlet and exhaust camshaft bearing caps 17 & 18.
NOTE: Mark bearing caps before removal for identification.
4. Fit locking tools in place of bearing caps 19 & 20. Tool No.1.825.041.000.
NOTE: Ensure locking tools aligned with respective cam profiles to prevent damage.
5. Fit timing belt in following order:
 - Crankshaft sprocket.
 - Guide pulley.
 - Exhaust camshaft sprocket.
 - Inlet camshaft sprocket.
 - Tensioner pulley.
 - Water pump pulley.
6. Ensure marks on belt aligned with marks on sprockets 21 & 22.
7. Tension timing belt to maximum. Use tool No.1.822.149.000 23.
8. Tighten tensioner nut 24.
9. Hold camshaft sprockets. Use tool Nos.1.822.155.000 and 1.822.146.000 15 & 16.
10. Tighten bolt of each camshaft sprocket.
11. Remove dial gauge 14.
12. Remove locking tools 19 & 20.
13. Fit bearing caps in correct locations.
14. Lubricate camshaft bearing cap bolts. Tighten bolts to 13-16 Nm.
15. Turn crankshaft two turns clockwise to TDC on No.1 cylinder 14.
16. Fit tensioning tool No.1.822.149.000 23.
17. Slacken tensioner nut 24.
18. Turn tensioner until pointer 25 aligned with hole 26.
19. Tighten tensioner nut to 21-26 Nm 24.
20. Ensure crankshaft at TDC on No.1 cylinder 14.
21. Align balancer shaft timing marks 7 & 8.
22. Fit balancer shaft belt.
23. Fit tensioning tool No.1.822.154.000 23.
24. Turn tensioner until hole 25 is aligned with centre of tensioner 26.
25. Tighten tensioner nut 24.
26. Turn crankshaft two turns clockwise to TDC on No.1 cylinder 14.
27. Ensure timing marks aligned 7, 8, 9 & 10.
28. Install components in reverse order of removal.
29. Tighten crankshaft pulley bolts to 24-26 Nm.

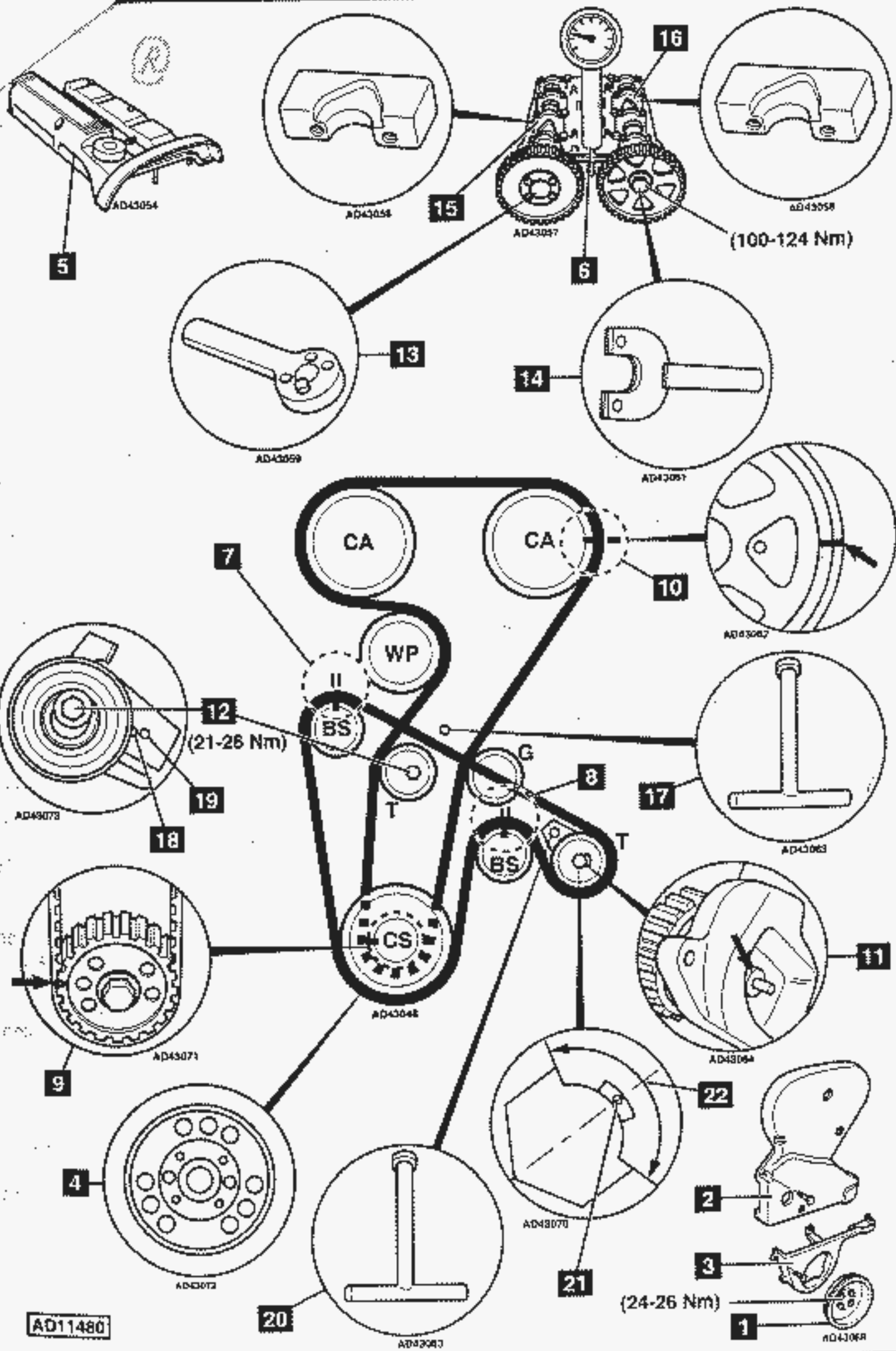

R

AD43054

AD43054

AD43057

AD43058

(100-124 Nm)

AD43059

AD43061

AD43062

AD43063

AD43073

(21-26 Nm)

AD43073

AD43071

AD43048

AD43064

AD43071

AD43072

AD43070

(24-26 Nm)

AD43068

AD11480

AD43083